

MODEL : GV-202 [Rising Stem Gate Valve, Outside Screw and Yoke]



Connection : ANSI 150, 300, 600

VTV VALVE, serving Multi-National end users in a wide range of applications in many industries including:

1. Palm Oil and Refinery Plant
2. Food Industries
3. Building Services
4. Cooling System
5. Petrochemical
6. Fire Protection System
7. Power Plant

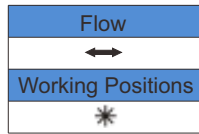

◆ SPECIFICATION

Valve Design	: API 600 Trims
Face to face	: ASME 16.10
Flange Connection	: ASME B16.5
Testing	: API 598
Rating P-T	: ASME B16.34

- ◆ Suitable for :
1. Water
 2. Oil
 3. Gases

◆ MATERIAL LIST

*Parts	Materials
*Body	ASTM A216-WCB
*Bonnet	ASTM A216-WCB
*Stem	ASTM A162-F6a
*Wedge	ASTM A216-WCB+Cr13 Overlay
Yoke Sleeve	ASTM A439 D-2
Gland Flange	ASTM A216-WCB
Handwheel	Ductile Iron
*Seat Ring	ASTM A105+STL Overlay
Back Seat	ASTM A276-420
*Gland	ASTM A276-420
Gasket	Spiral wound graphite
Packing	Graphite
Retaining nut	Carbon steel
Bonnet stud/nut	ASTM A193-B7 / ASTM A 194-2H
Gland bolt/nut	ASTM A193-B7 / ASTM A 194-2H
Spacer Ring	ASTM A276-420
Handwheel nut	Carbon steel
Grease fitting	Steel
Yoke	ASTM A216-WCB

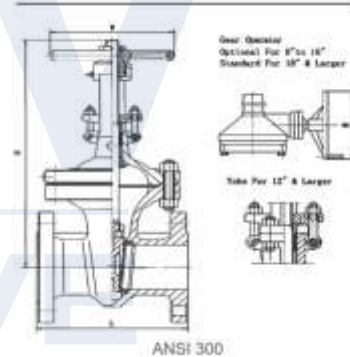
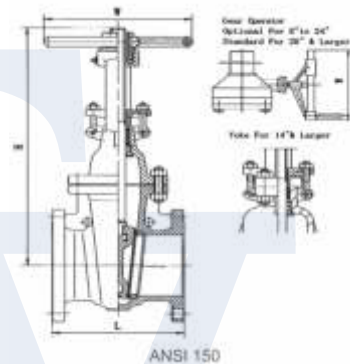

*Optional : SS304 | SS316

◆ DIMENSIONS AND WEIGHTS ANSI 150

NPS	in	2	2-1/2	3	4	5	6	8	10	12	14	16	18	20	24	26	28	30
DN	mm	50	65	80	100	125	150	200	250	300	350	400	450	500	600	650	700	750
L (RF)	mm	128	191	203	229	254	267	292	330	356	381	406	432	457	508	559	610	610
W	mm	200	200	250	300	300	300	350	400	450	500	560	600	680	760	610	610	610
H (Open)	mm	386.5	434.5	480.5	584.5	68.1	765	956	1149	1350.5	1508	1703	1892	2119	2500	2806	2960	3148
WT (Kg)	RF	18	25	32	50	64	77	121	178	265	362	463	621	792	1144	1570	1900	3310

◆ DIMENSIONS AND WEIGHTS ANSI 300

NPS	in	2	2-1/2	3	4	5	6	8	10	12	14	16	18	20	24	26	28
DN	mm	50	65	80	100	125	150	200	250	300	350	400	450	500	600	650	700
L (RF)	mm	216	241	283	305	381	403	419	457	502	762	836	914	991	1143	1245	1346
W	mm	200	200	250	250	300	350	400	450	500	560	600	610	610	610	610	610
H (Open)	mm	410	453	509	612	670	805	1000	1209	1416	1582	1725	1959	2194	2598	2986	3120
WT (Kg)	RF	23	35	50	71	100	144	209	322	482	683	950	1145	1634	2660	3090	3312

For specification of ANSI 600, ANSI 900 ... ANSI 2500, please call our sales engineer at sales@bjmsgroup.com

Specification is subject to change without prior notice